

CAS Foundation RMD

67 Broadway, Somerville, MA 02145

Owner:

CAS Foundation, LLC
 9 Bartlet Street, unit #335
 Andover, MA 01810
 (978) 474-8008

Architect:

Elton + Hampton Architects
 103 Terrace Street
 Roxbury, MA 02120
 (617) 708-1071

Electrical Engineer:

John J. Murphy Electrical
 379 Liberty Street
 Rockland, MA 02370
 (781) 792-0059

Mechanical Engineer:

Norian Siani Engineering, Inc
 43 Bradford Street, 3rd Floor
 Concord, MA 01742
 (781) 398-2250

Security Consultants:

Lan-tel
 1400 Providence Highway
 Suite 3100
 Norwood, MA 02062
 Roxbury, MA 02120
 (857) 939-8181

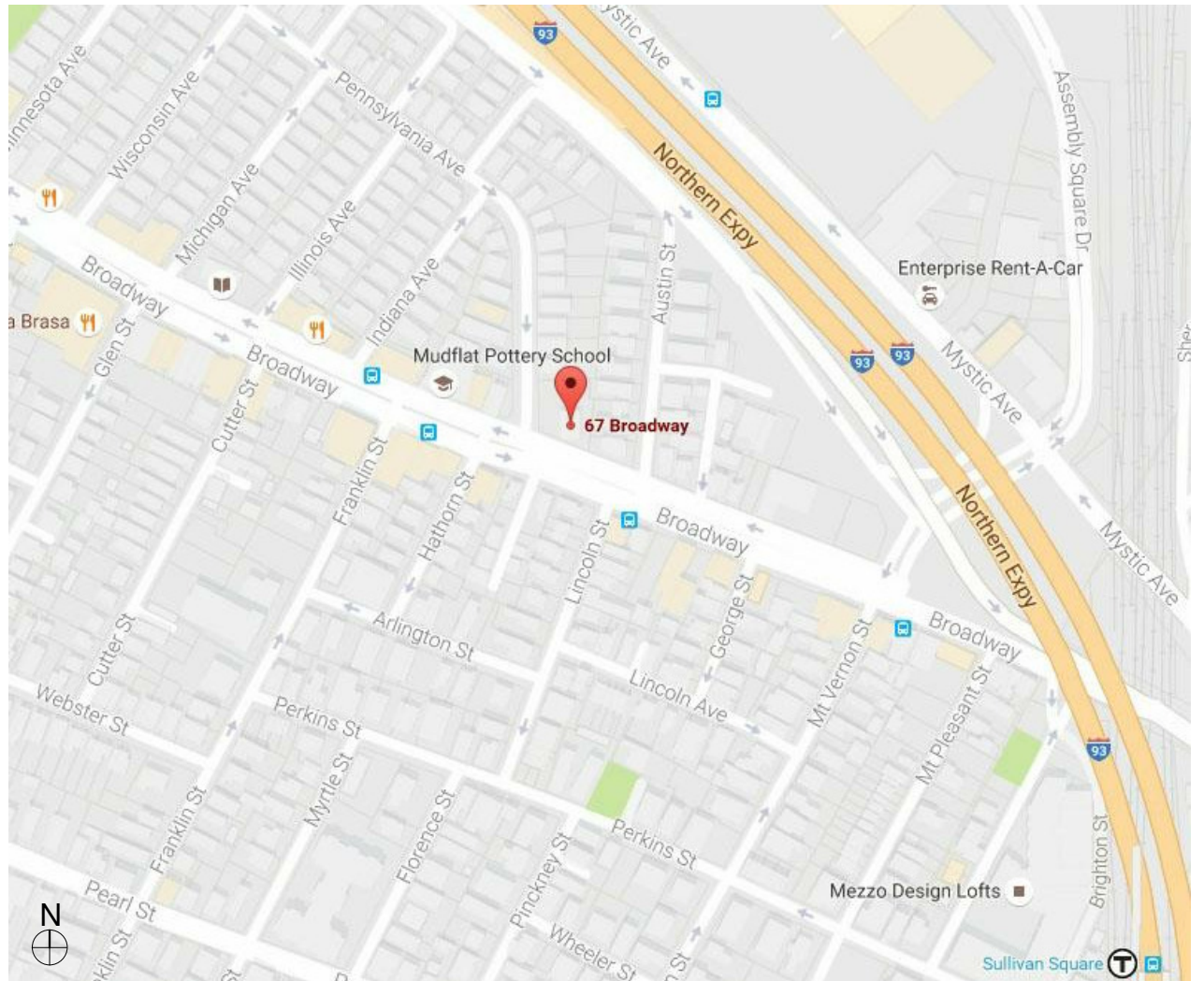

DRAWING LIST

- COVER PAGE
- Context Map/ Distance to Schools/ Daycare
- Travel to Sullivan Square
- MBTA Bus Routes
- Mortgage Plan
- A.00.00 Site Plan
- X.00.00 Existing Basement Floor Plan
- X.00.01 Existing First Floor Plan
- X.00.02 Existing Second Floor Plan
- X.00.03 Existing Third Floor Plan
- A.00.01 Proposed Basement Plan
- A.00.02 Proposed First Floor Plan
- A.00.03 Proposed Second Floor Plan
- A.00.04 Proposed Third Floor Plan
- A.00.05 Building Elevations
- A.00.06 Schedules, Wall Types & Interior Signage
- SC.00.01 First Floor Security Plan



Address: 67 Broadway, Somerville, MA
 Zoning District: Medical Marijuana Overlay District
 Zoning Map: CCD55

	REQUIRED	EXISTING	PROPOSED	COMMENT
DISTANCE TO SCHOOLS/DAYCARES	0	420	420	SECTION 7.15 (b)
FACILITY SIZE	<10,000	4294	4294	SECTION 7.15
MIN LOT SIZE	NA	12034	12034	SECTION 7.11
MAX GROUND COVER	80%	21%	21%	SECTION 7.11
LANDSCAPE AREA	10%	2.50%	2.50%	SECTION 7.11
FLOOR AREA RATIO	3	0.356	0.356	SECTION 7.11
MAX HEIGHT	55	35'-6"	35'-6"	SECTION 7.11
FRONT YARD	NA	3'/17'	3'/17'	SECTION 7.11
SIDE YARD	NA	3'/44'	3'/44'	SECTION 7.11
MINIMUM FRONTAGE	30	94.26'	94.26'	SECTION 7.11
PERVIOUS AREA	NA	5%	5%	SECTION 7.11
PARKING	3	14	14	ARTICLE 9: 1 CAR/1500SF
LOADING	0	0	0	ARTICLE 9: LESS THAN 5000 SF

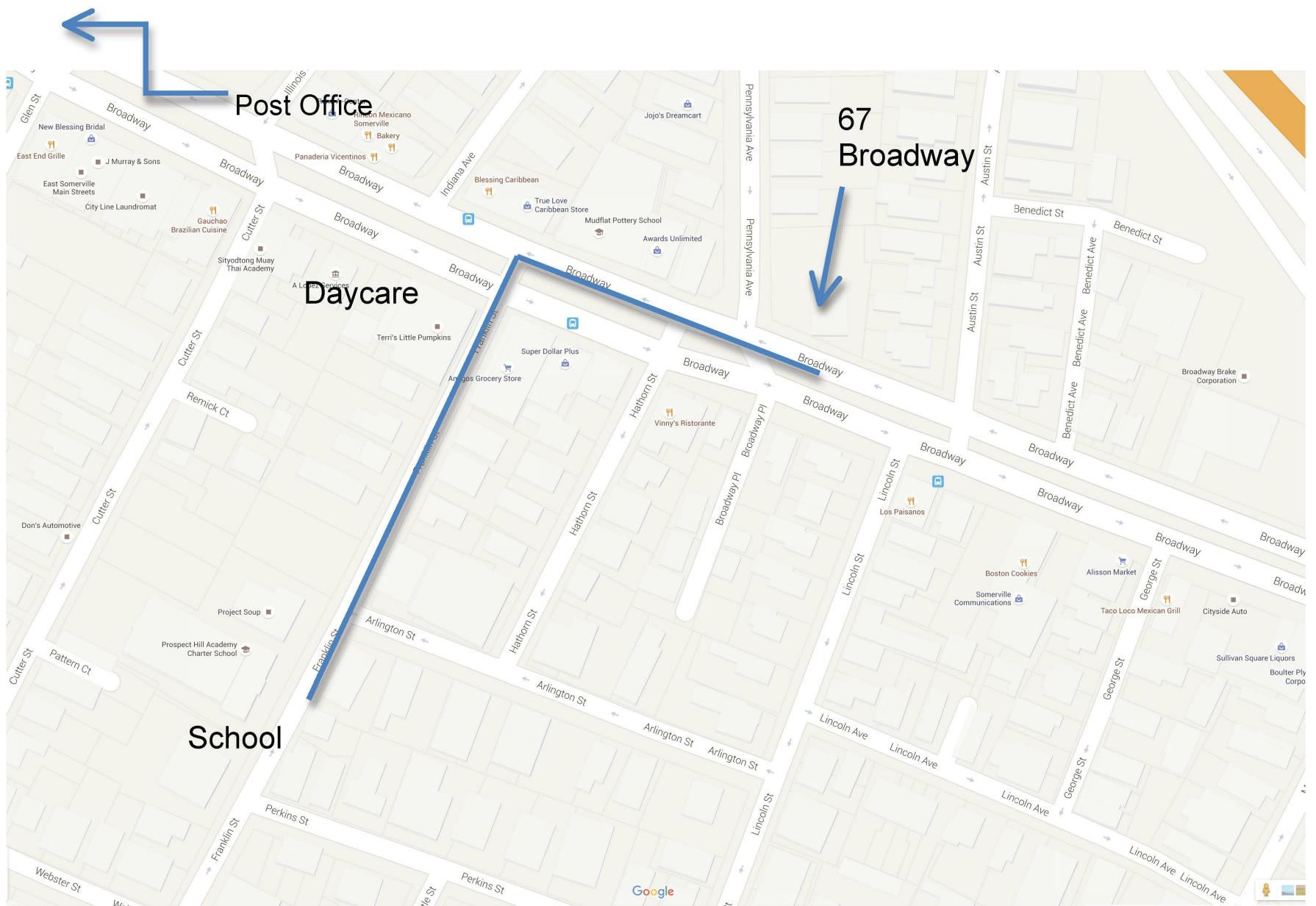

Figure 4. Nearest school is 0.2 miles walking distance. Post Office is 0.7 miles walking up Broadway. Closest daycare is 427 feet walking distance.

Elton + Hampton Architects

CAS FOUNDATION
67 Broadway
Somerville, MA 02145

Context Map/ Distance to Schools/
Daycare

Project number	DISPENSARY
Date	12.23.16
Drawn by	B. Hampton
Checked by	B. Hampton

Scale

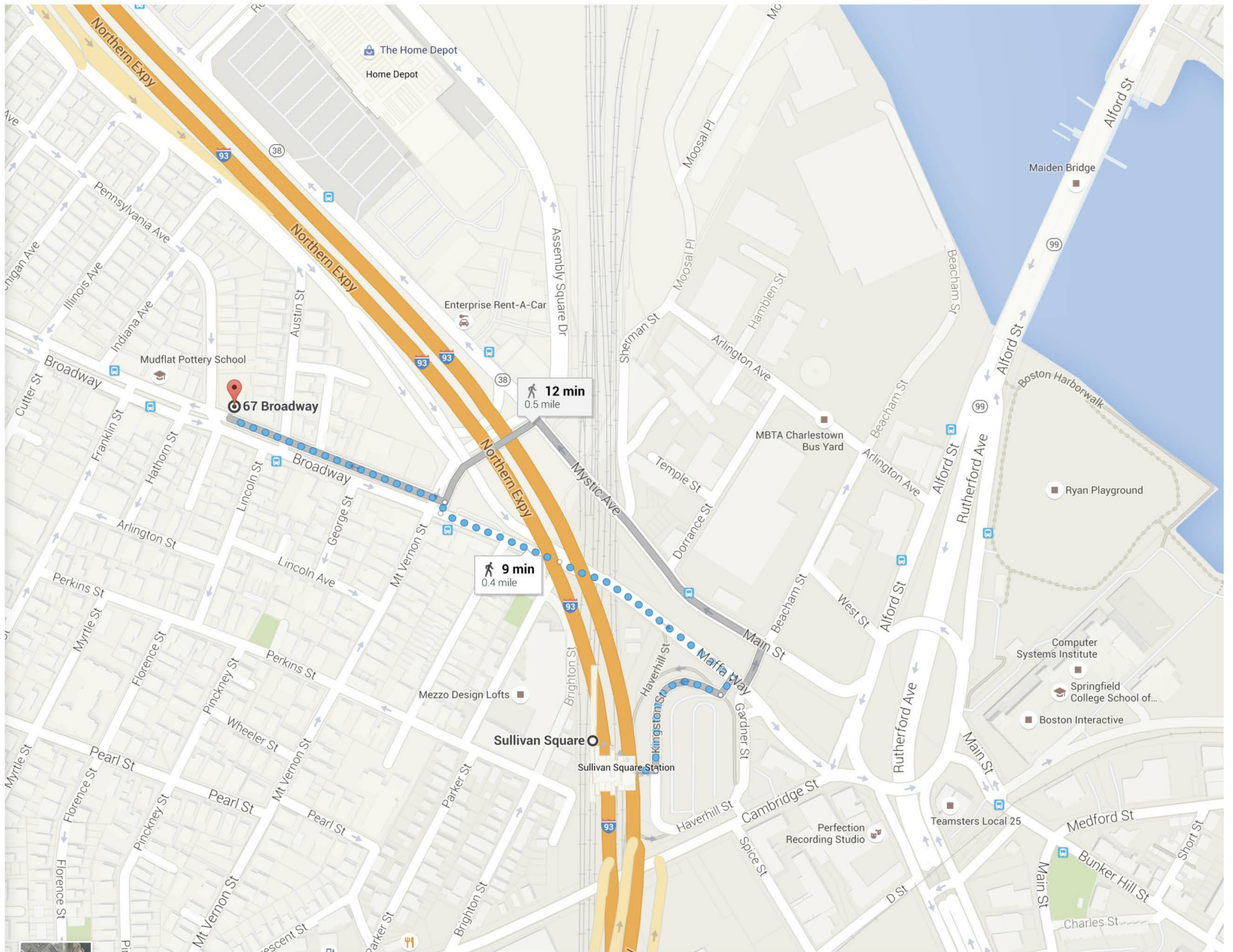
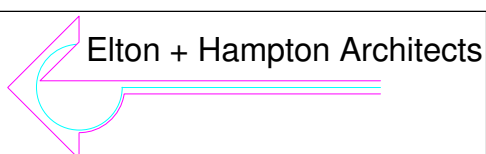

Figure 1. Walking times from Sullivan Square T Station to 67 Broadway: 9 minute walk.
 MBTA Orange Line trains all serve Wellington to Forest Hills.



CAS FOUNDATION
 67 Broadway
 Somerville, MA 02145

Travel to Sullivan Square

Project number	DISPENSARY
Date	12.23.16
Drawn by	B. Hampton
Checked by	B. Hampton

Scale

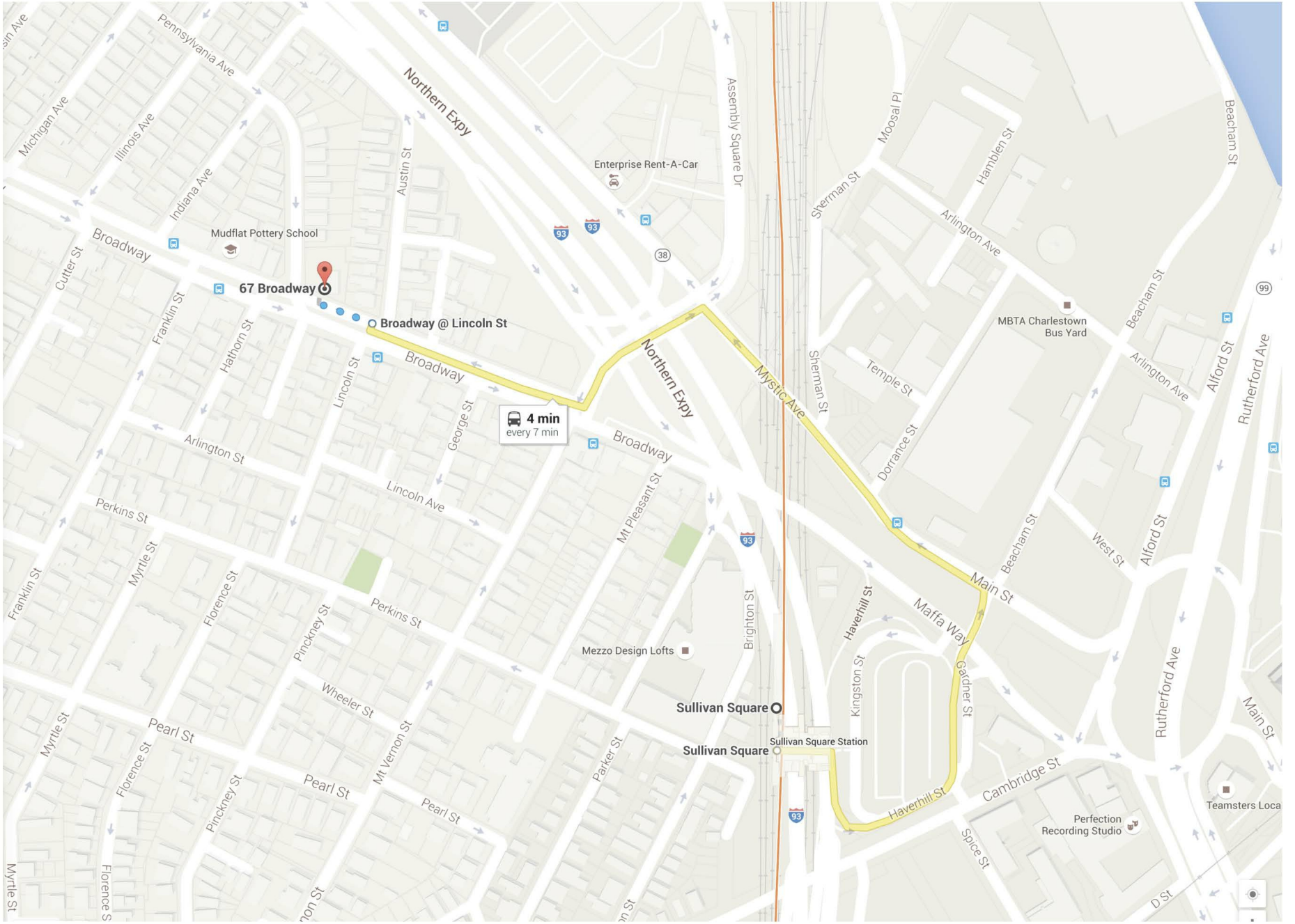
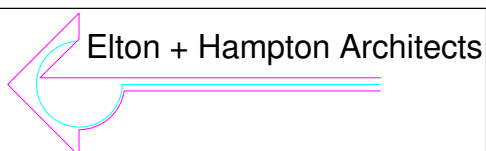

Figure 1. #89, #90, and #101 Buses from Sullivan Square T Station to 67 Broadway: 4 minute ride. MBTA Orange Line trains all serve Wellington to Forest Hills.



Elton + Hampton Architects

CAS FOUNDATION
67 Broadway
Somerville, MA 02145

MBTA Bus Routes

Project number	DISPENSARY
Date	12.23.16
Drawn by	B. Hampton
Checked by	B. Hampton

Scale

HABERSTROH

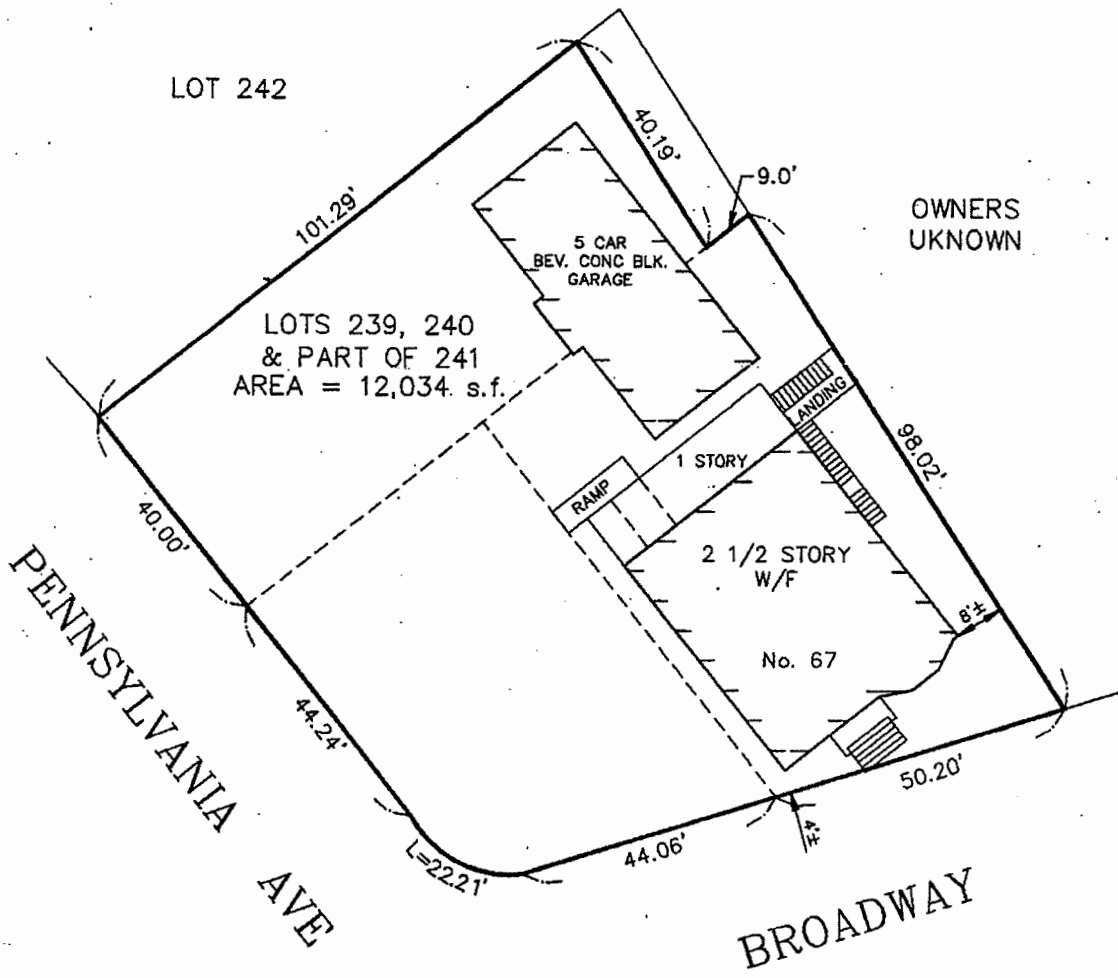

LOT 242

LOTS 239, 240
& PART OF 241
AREA = 12,034. s.f.

OWNERS
UNKNOWN

PENNSYLVANIA
AVE

BROADWAY

NOTES:
 ALL TIES SUBJECT TO WHAT AN ACCURATE INSTRUMENT SURVEY WOULD REVEAL. THIS PLOT PLAN IS NOT TO BE USED FOR PROPERTY LINE DETERMINATION, THE LOCATION OF FENCES OR THE LOCATION OF ANY OTHER STRUCTURES. THIS CERTIFICATION IS MADE TO: JOHN & DANIELLE HABERSTROH AND BECOMES NULL AND VOID UPON FUTURE CONVEYANCE. I HEREBY CERTIFY THAT I HAVE EXAMINED THE PREMISES AND ALL BUILDINGS AND EASEMENTS ARE LOCATED ON THE GROUND AS SHOWN. I FURTHER CERTIFY THAT THE PRINCIPAL BUILDING, WHEN CONSTRUCTED, DID CONFORM TO THE DIMENSIONAL ZONING LAWS OF: **SOMERVILLE**. I HEREBY CERTIFY THAT THE PROPERTY IS NOT LOCATED IN AN ESTABLISHED FLOOD HAZARD AREA.

COMMUNITY No. 250214
REVISION DATE: JULY 17, 1986

Angelo B. Veneziano 10/9/97
 ANGELO B. VENEZIANO, P.E. P.L.S. Date

PLOT PLAN OF LAND
 IN
 SOMERVILLE, MASS.



ABV SURVEY
 15 HALL STREET, MEDFORD, MASS. 02155
 781-396-4466 FAX: 781-396-8052

SCALE: 1" = 30'
 TITLE REF: BK. 17965 PAGE 380
 DATE: OCTOBER 9, 1997
 FILE No. 16-682-97

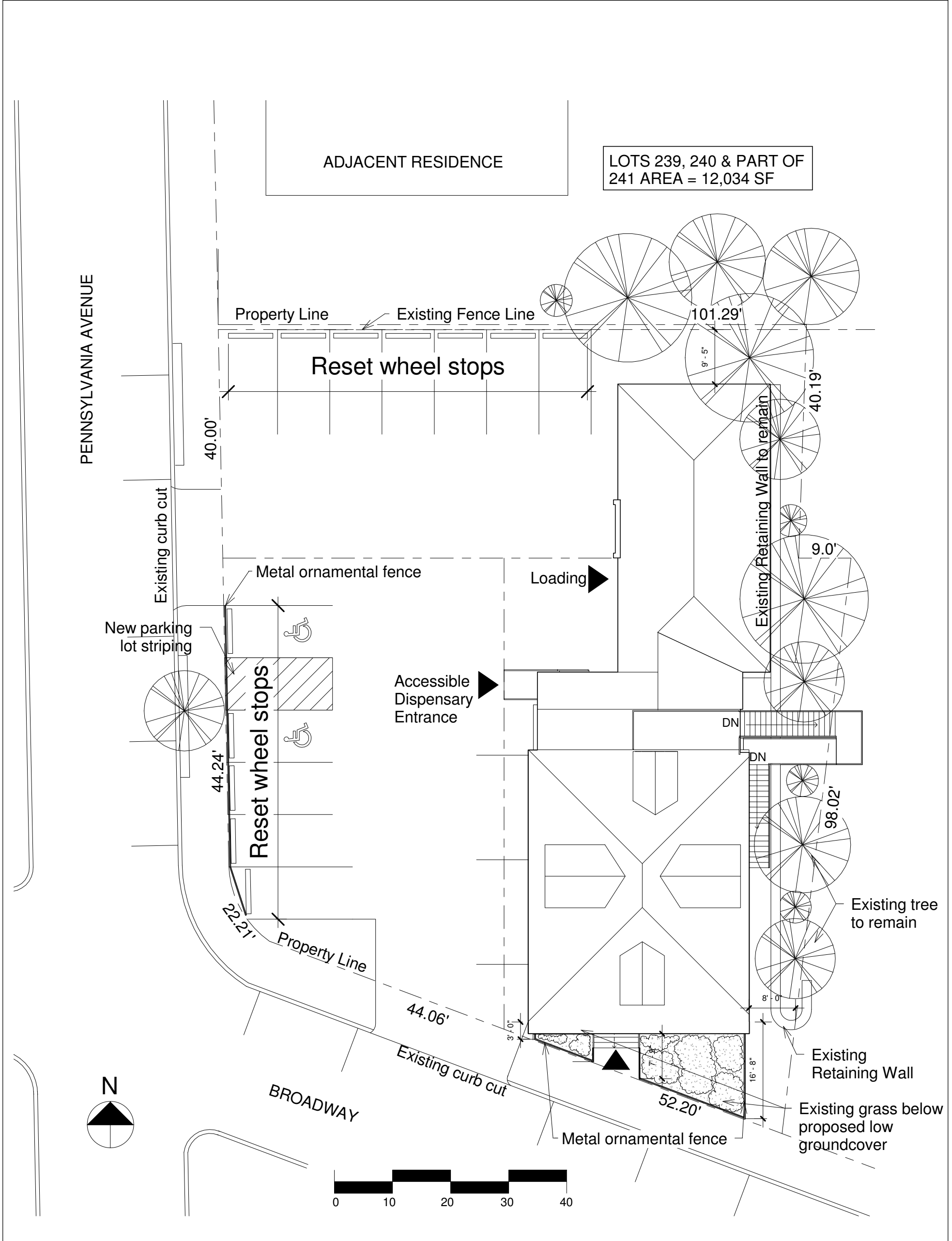

1 Site
1/16" = 1'-0"

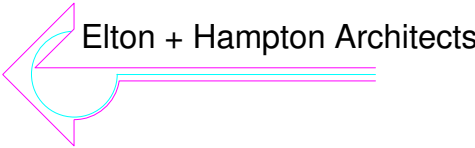
	CAS FOUNDATION 67 Broadway Somerville, MA 02145	Site Plan		A.00.00
		Project number DISPENSARY Date 12.23.16 Drawn by M. Worth Checked by B. Hampton	Scale 1/16" = 1'-0"	

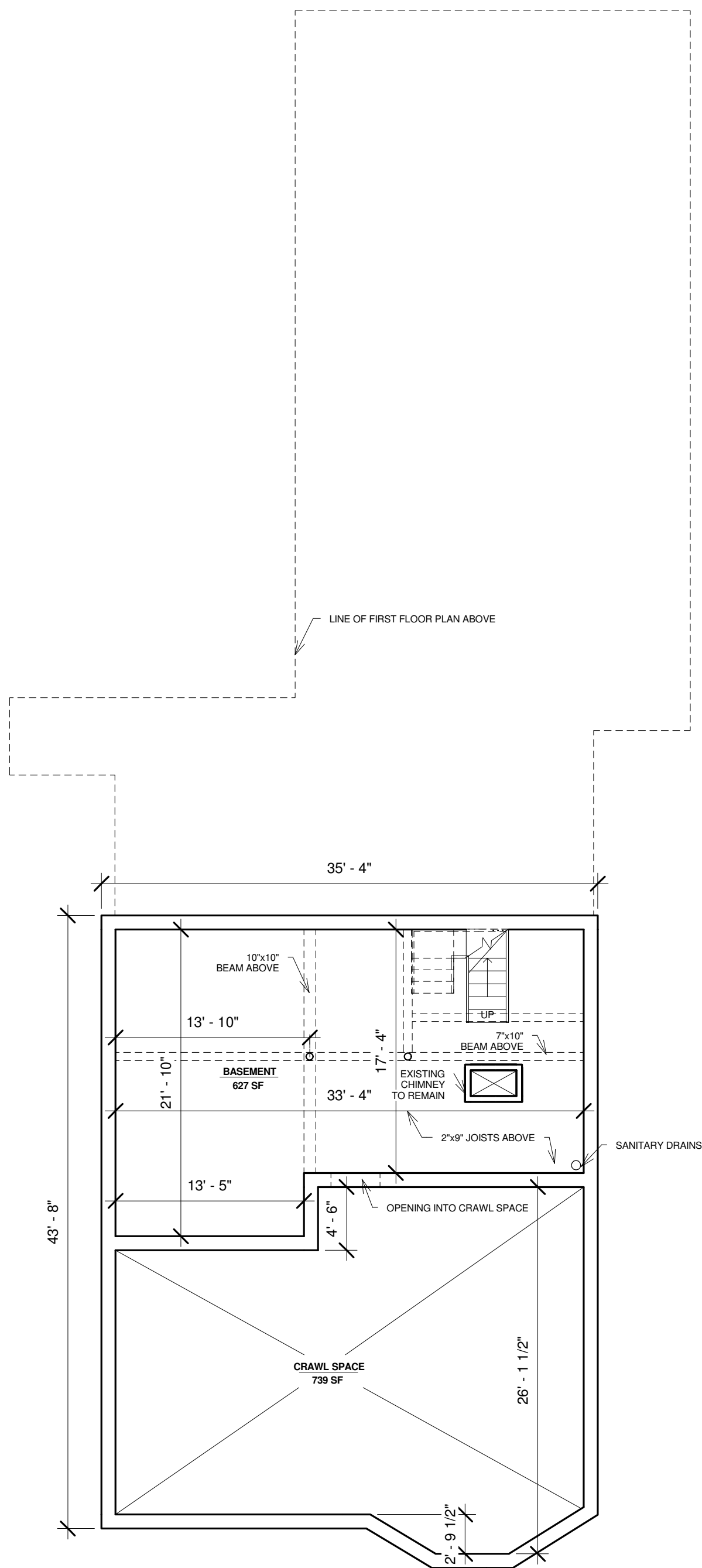

1 Basement
1/8" = 1'-0"

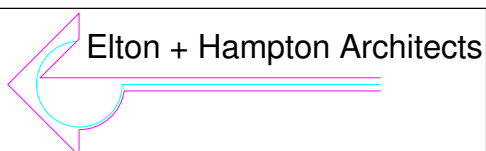

Elton + Hampton Architects

CAS Foundation
67 Broadway
Somerville, MA 02145

Existing Basement Floor Plan

Project number	Dispensary
Date	11.30.16
Drawn by	Melissa D. Worth
Checked by	Bruce Hampton

X.00.00

Scale 1/8" = 1'-0"

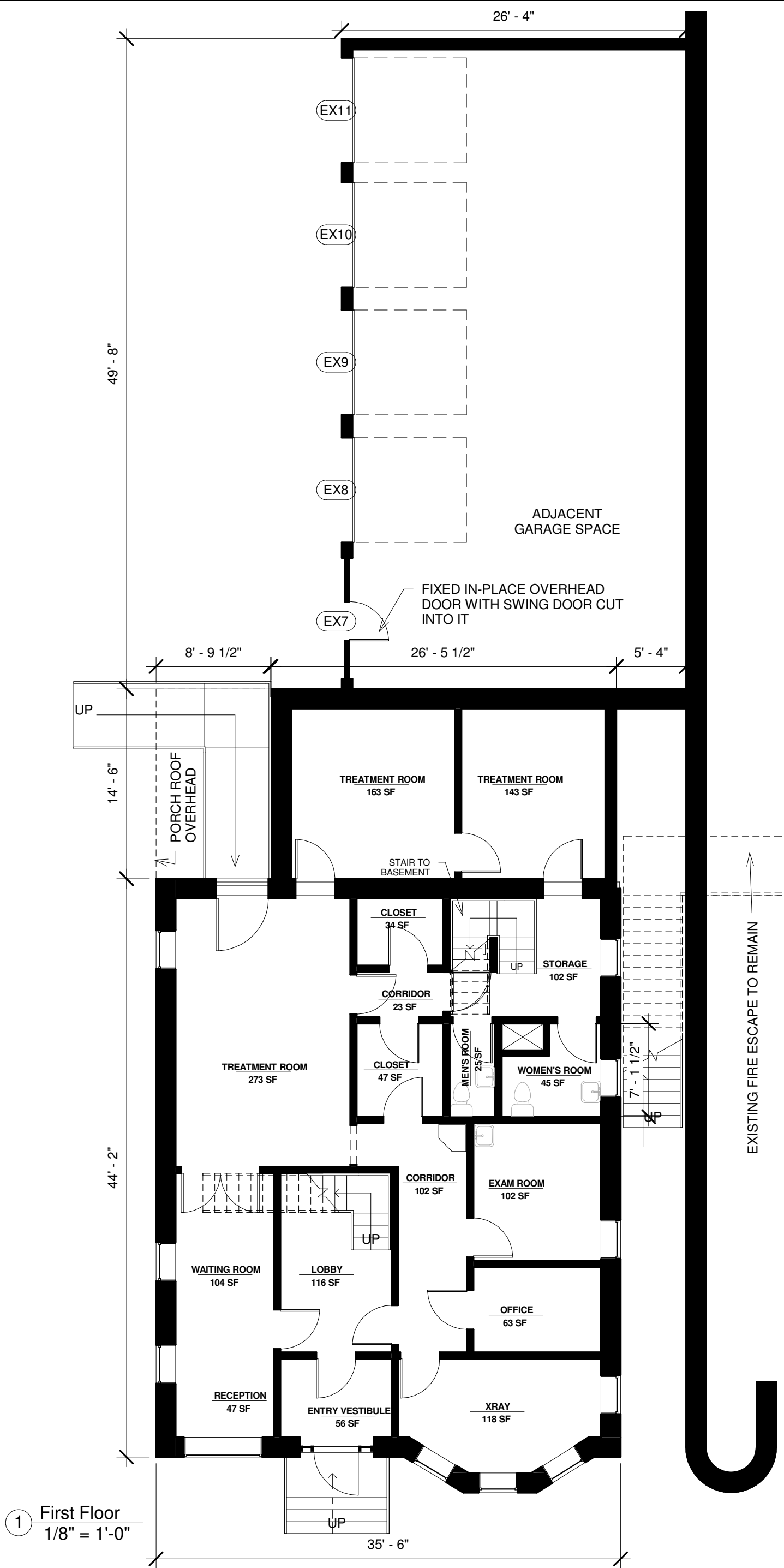

① First Floor
1/8" = 1'-0"

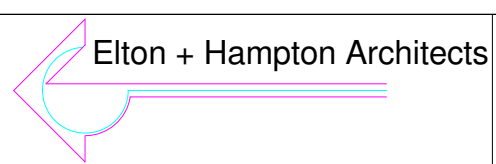

Elton + Hampton Architects

CAS Foundation
67 Broadway
Somerville, MA 02145

Existing First Floor Plan

Project number	Dispensary
Date	11.30.16
Drawn by	M.P. Worth
Checked by	B.Hampton

X.00.01

Scale 1/8" = 1'-0"

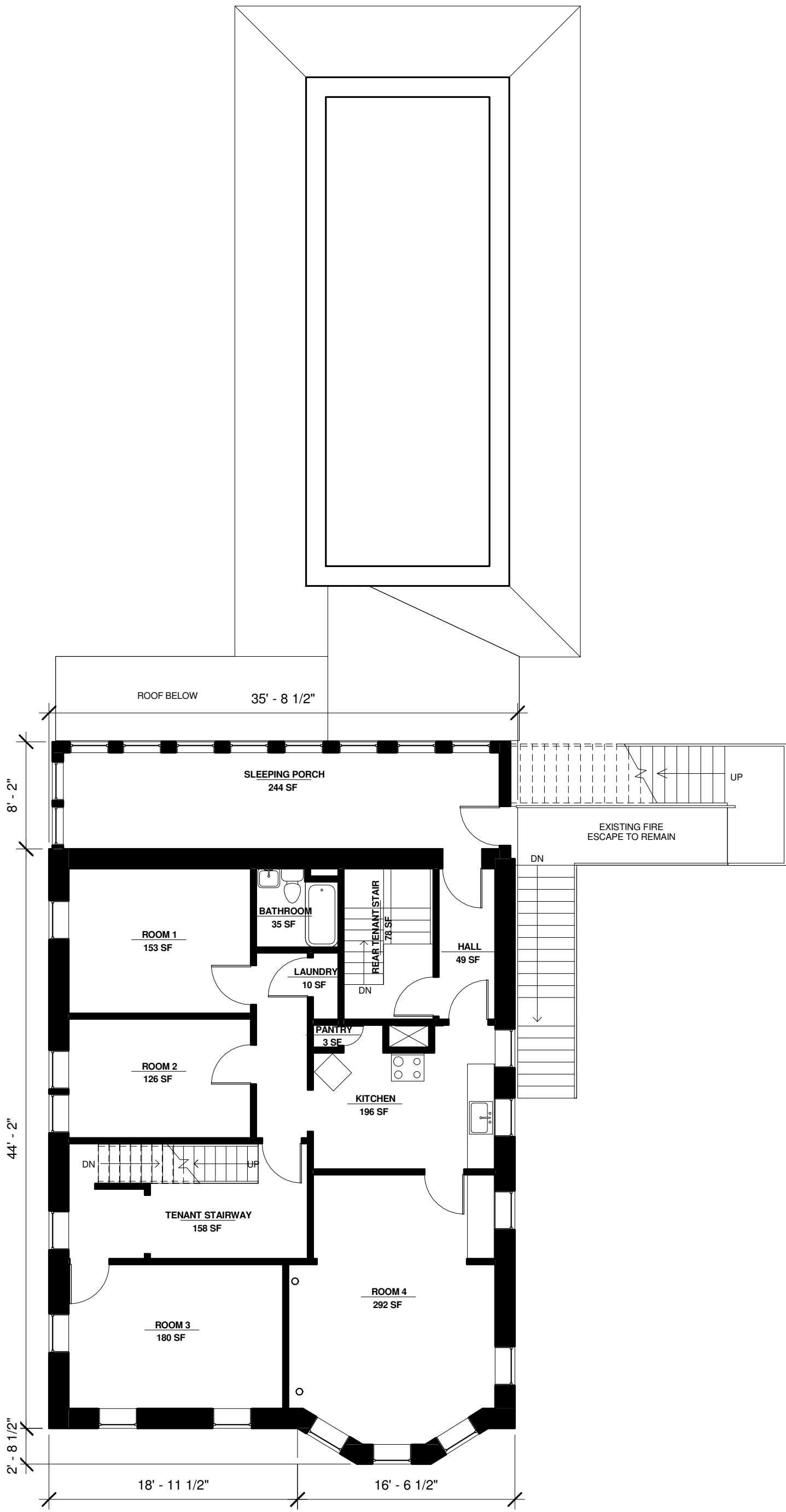

1 Second Floor
1/8" = 1'-0"

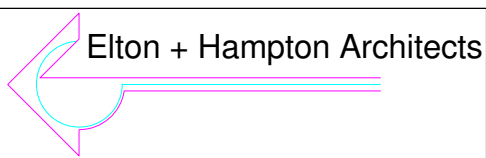

CAS Foundation
67 Broadway
Somerville, MA 02145

Existing Second Floor Plan

Project number	Dispensary
Date	11.30.16
Drawn by	M.P. Worth
Checked by	B. Hampton

X.00.02

Scale 1/8" = 1'-0"

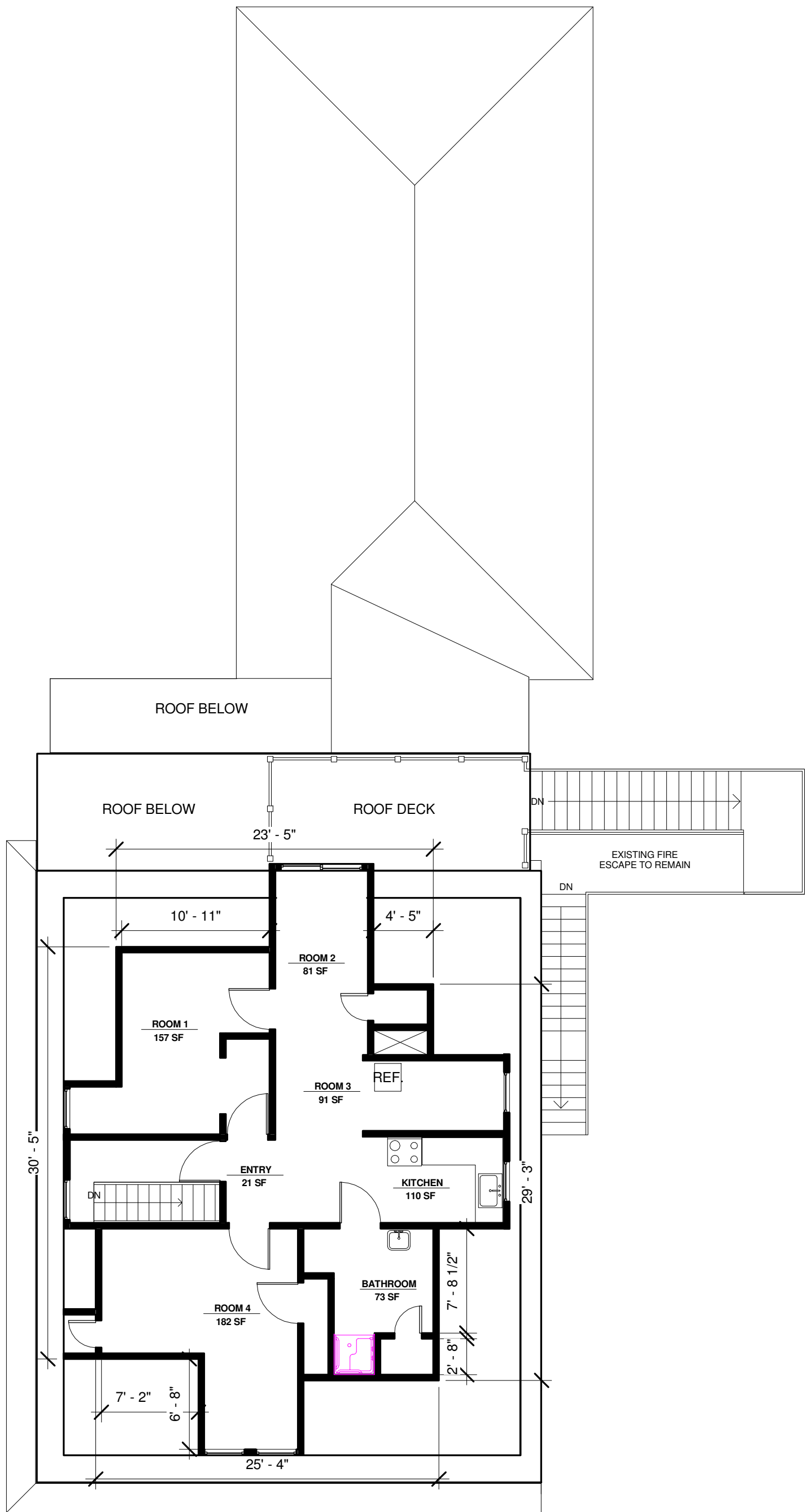

EXISTING TO REMAIN.
OFFICE USE TO BE DETERMINED.

① Third Floor
1/8" = 1'-0"

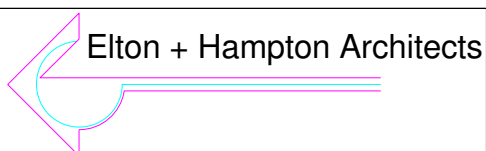

CAS Foundation
67 Broadway
Somerville, MA 02145

Existing Third Floor Plan

Project number	Dispensary
Date	11.30.16
Drawn by	Melissa D. Worth
Checked by	Bruce Hampton

X.00.03

Scale 1/8" = 1'-0"

SQUARE FOOTAGE	
Crawl Space	739sf
Basement Space	627sf
TOTAL	1,366sf

LINE OF FIRST FLOOR PLAN ABOVE

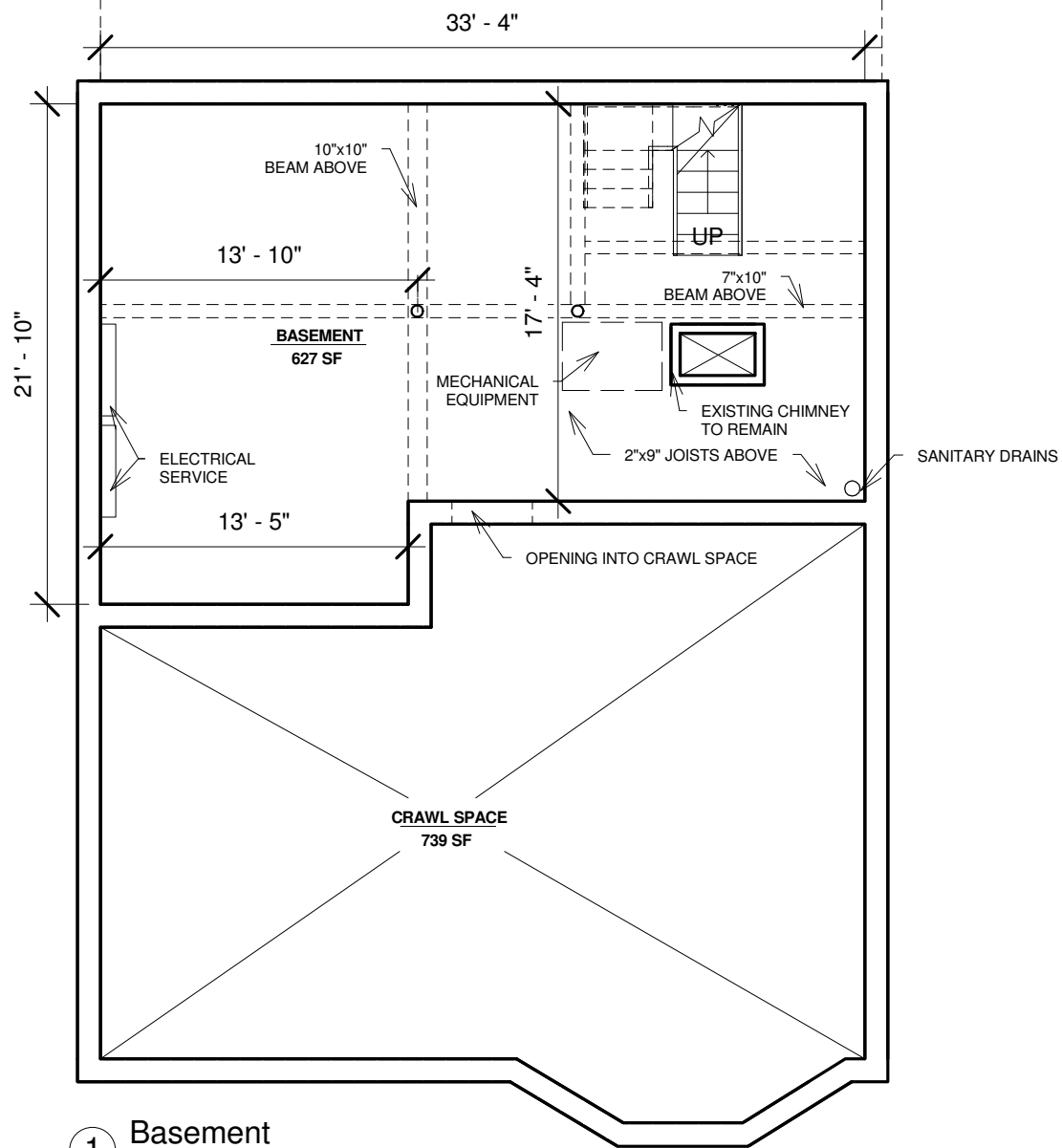

① Basement
1/8" = 1'-0"

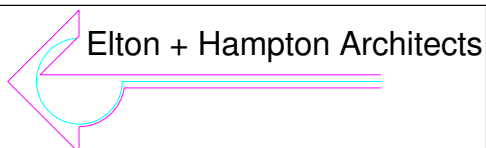

CAS FOUNDATION
67 Broadway
Somerville, MA 02145

Basement Plan

Project number	DISPENSARY
Date	12.23.16
Drawn by	Melissa D. Worth
Checked by	Bruce Hampton

A.00.01

Scale 1/8" = 1'-0"

Design Narrative for 67 Broadway in Somerville, MA

- **Proposed construction or demolition:**
The renovation of an existing medical office to be used as a Registered Medical Marijuana Dispensary (RMD) pursuant the MA DPH Medical Marijuana program.
- **All uses:**
The facility shall be used as a retail dispensary for qualified medical marijuana patients of the Commonwealth; Home delivery services shall be provided; Administrative offices shall be located on 2nd and 3rd floors. There is no cultivation, extraction, cooking, production, or consumption on premises.
- **Who the project is intended to serve:**
Massachusetts medical marijuana patients appropriately registered with the DPH within a 5 mile radius.
- **Expected number of employees, and/or occupants:**
There will be approximately 6-10 employees on site at any given time and up to 40 total employees.
- **Methods and hours of operation:**
Retail and delivery operations: Mon-Sat 10:00 am – 8:00 pm. Sundays 10:00 – 4:00 pm.
Office Hours: 8:00 am – 9:00 pm

SQUARE FOOTAGE	
Garage Space	739sf
Occupiable Space	1,875sf
TOTAL	2,614sf

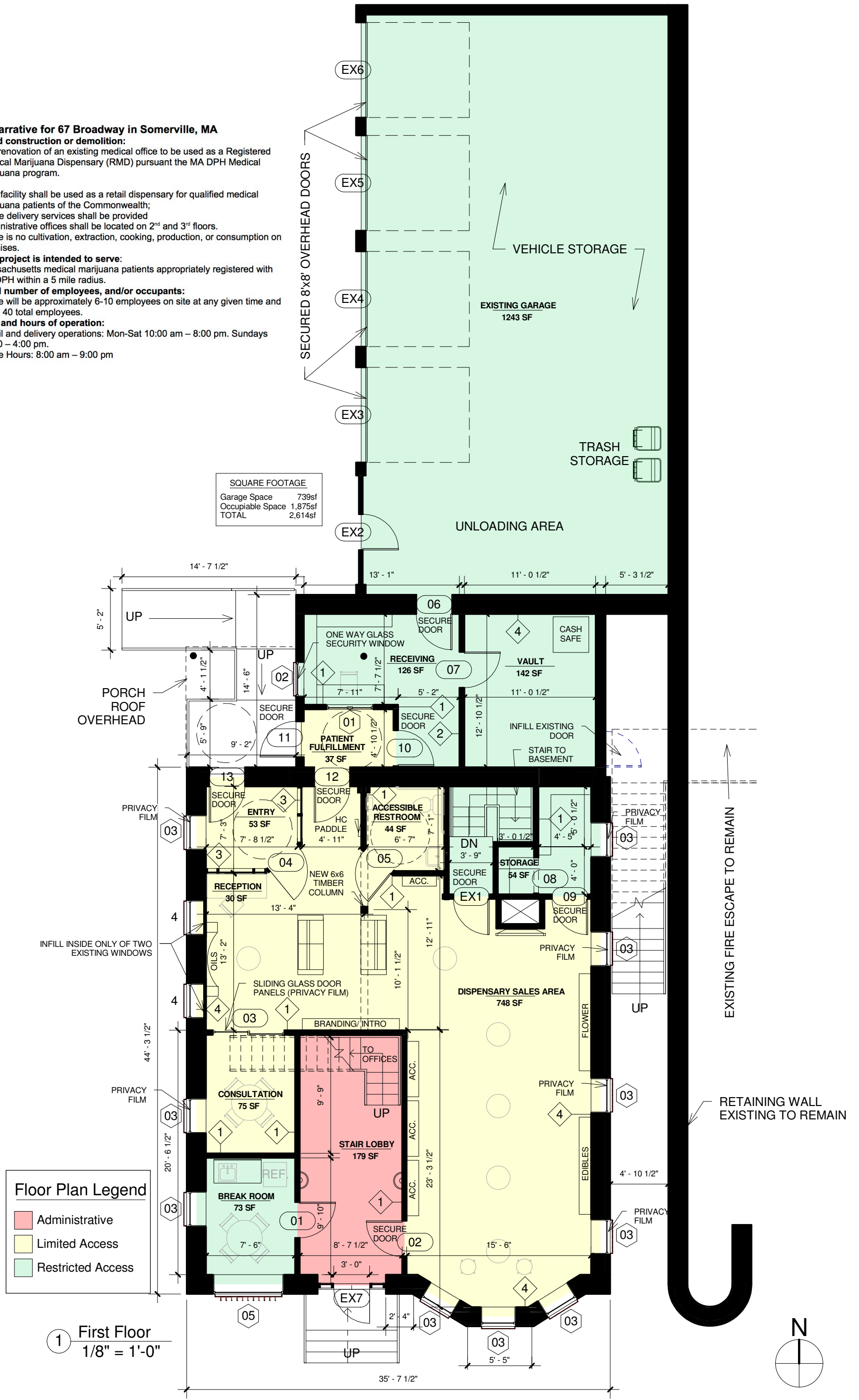

Floor Plan Legend	
	Administrative
	Limited Access
	Restricted Access

1 First Floor
1/8" = 1'-0"

	CAS FOUNDATION 67 Broadway Somerville, MA 02145	Proposed First Floor Plan									
		<table border="1" style="width:100%; border-collapse: collapse;"> <tr> <td style="width: 50%;">Project number</td> <td style="width: 50%;">DISPENSARY</td> </tr> <tr> <td>Date</td> <td>12.23.16</td> </tr> <tr> <td>Drawn by</td> <td>M.P. Worth</td> </tr> <tr> <td>Checked by</td> <td>B.Hampton</td> </tr> </table>	Project number	DISPENSARY	Date	12.23.16	Drawn by	M.P. Worth	Checked by	B.Hampton	A.00.02
Project number	DISPENSARY										
Date	12.23.16										
Drawn by	M.P. Worth										
Checked by	B.Hampton										

Floor Plan Legend

Restricted Access

SQUARE FOOTAGE

Porch Space 253sf
 Occupiable Space 1,472sf
 TOTAL 1,725sf

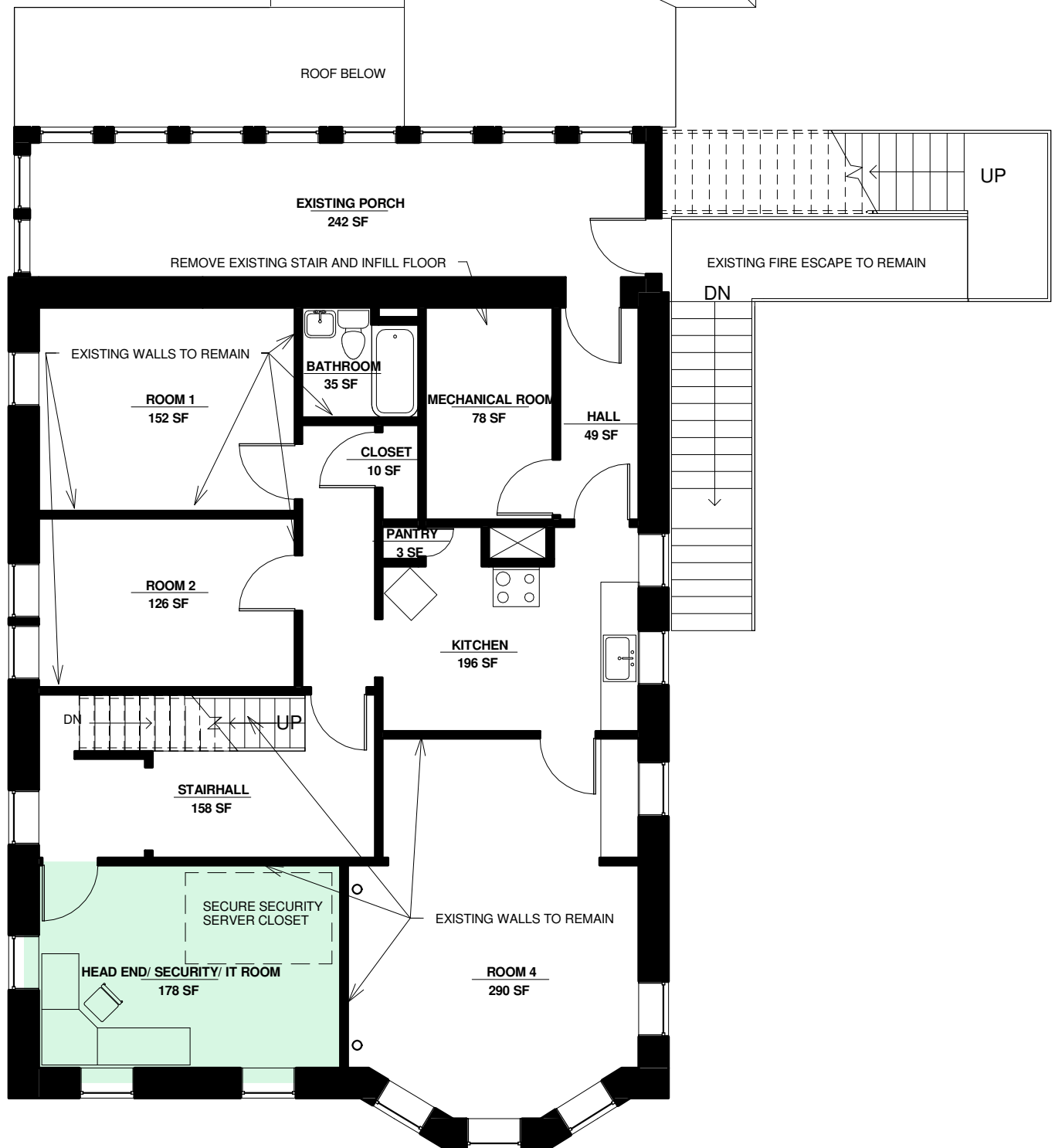

1 Second Floor
 1/8" = 1'-0"

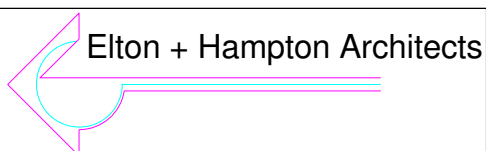
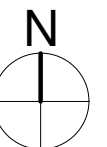

CAS FOUNDATION
 67 Broadway
 Somerville, MA 02145

Second Floor Plan

Project number	DISPENSARY
Date	12.23.16
Drawn by	M.P. Worth
Checked by	B. Hampton

A.00.03

Scale 1/8" = 1'-0"

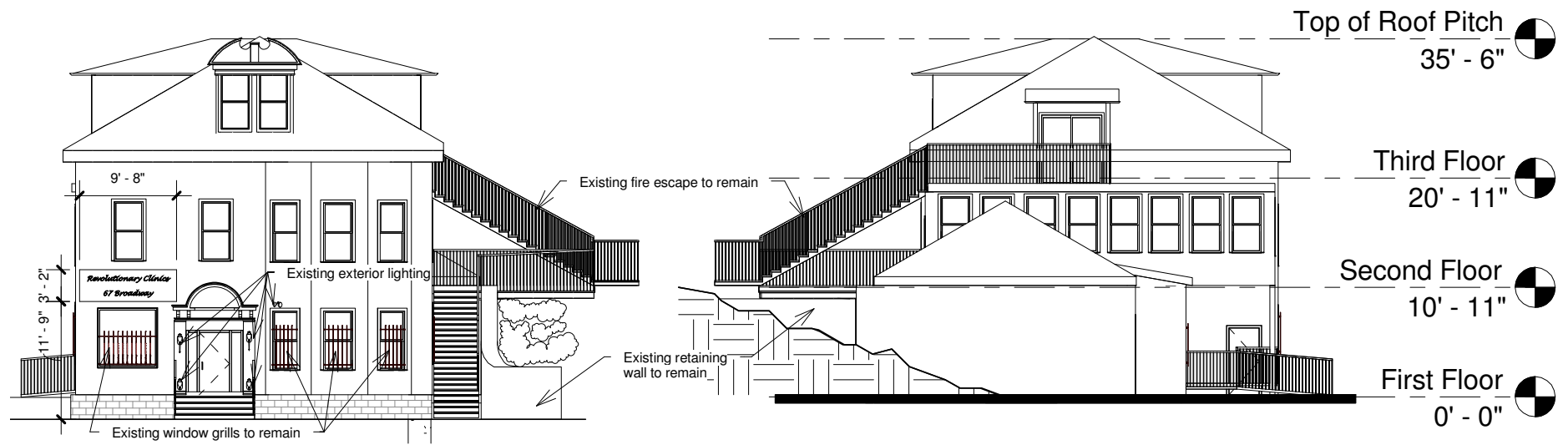

1 Front Elevation
1/16" = 1'-0"

2 Rear Elevation
1/16" = 1'-0"

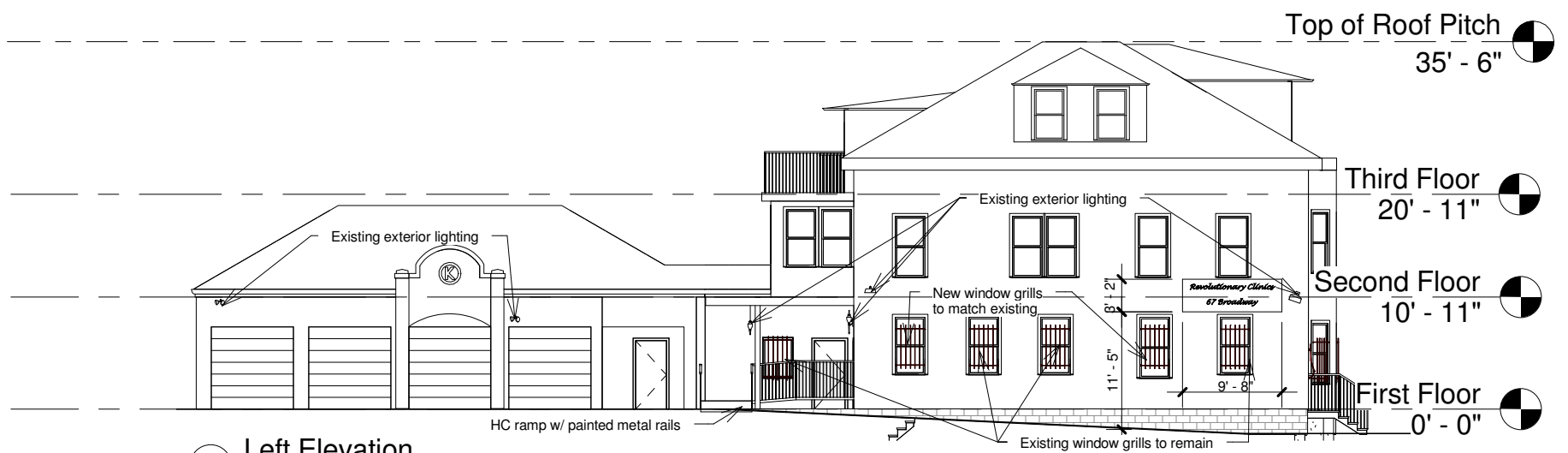

3 Left Elevation
1/16" = 1'-0"

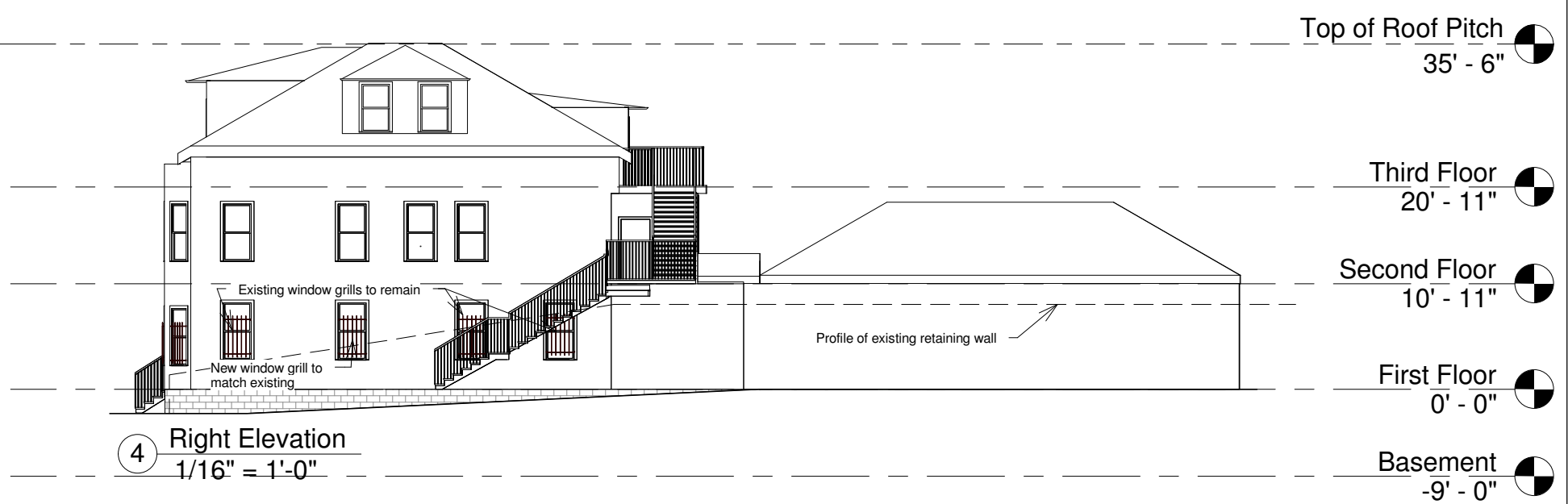

4 Right Elevation
1/16" = 1'-0"

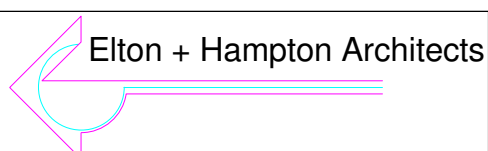

Elton + Hampton Architects

CAS FOUNDATION
67 Broadway
Somerville, MA 02145

Building Elevations

Project number	DISPENSARY
Date	12.23.16
Drawn by	Melissa D. Worth
Checked by	Bruce Hampton

A.00.05

Scale 1/16" = 1'-0"

Door Schedule

Mark	Construction Type	Location	Type	Thickness	Fire Rating	Material	Door Type	Frame Type	Finish	Hinges	Category	ANSI	Kick Plates	Panic Bar	Closer	Comments
01	Swing	Break Room	36" x 80"	0' - 1 3/8"	60 min.	Metal	Flush	Metal	Painted	3	Passage	F75	Yes	Yes	Yes	FOB access
02	Swing	Patient Exit Vestibule	36" x 80"	0' - 1 3/8"	60 min.	Full glass	Flush	Existing	Painted	3	Passage	F75	Yes	Yes	Yes	FOB access
03	Sliding	Consultation	72" x 82"	0' - 2"		Full Glass	Flush	Metal	Painted		Passage	F75				
04	Swing	Entry	Storefront	0' - 2"		Full Glass	Flush	Metal	Painted	3	Passage	F75			Yes	FOB access
05	Swing	Accessible Restroom	36" x 80"	0' - 1 3/8"		Metal	Flush	Metal	Painted	3	Privacy	F76A			Yes	
06	Swing	Existing Garage	36" x 80"	0' - 1 3/8"		Existing	Flush	Existing	Painted	3	Storeroom	F86	Yes	Yes	Yes	FOB access
07	Swing	Vault	36" x 80"	0' - 1 3/8"		Metal	Flush	Metal	Painted	3	Storeroom	F86			Yes	FOB access
08	Finished Opening	Closet	36" x 80"	0' - 1 3/8"		N/A										
09	Swing	Point of Sales	36" x 80"	0' - 1 3/8"		Metal	Flush	Metal	Painted	3	Passage	F75			Yes	FOB access
10	Swing	Fulfillment	36" x 80"	0' - 1 3/8"		Metal	Flush	Metal	Painted	3	Passage	F75			Yes	FOB access
11	Swing	Fulfillment Exit	36" x 80"	0' - 1 3/8"		Metal	Flush	Metal	Painted	3	Passage	F75		Yes	Yes	FOB access
12	Swing	Patient Fulfillment	36" x 80"	0' - 1 3/8"		Full Glass	Flush	Metal	Painted	3	Passage	F75			Yes	FOB access, secure, alarmed, privacy film
13	Swing	Existing Rear Accessible Entrance	36" x 80"	0' - 1 3/8"		Existing	Flush	Existing	Painted	3	Exit		Yes	Yes	Yes	FOB access
EX1	Swing	Existing Basement Stair	36" x 80"	0' - 1 3/8"	60 min.	Existing	Flush	Existing	Painted	3	Storeroom	F86			Yes	FOB access
EX2	Swing	Existing Unloading Area	36" x 80"	0' - 1 3/8"	60 min.	Existing	Flush	Existing	Painted	3	Storeroom	F86			Yes	FOB access
EX3	Overhead	Existing Overhead Garage 1	8' x 8'	0' - 1 1/2"		Existing	Flush	Existing	Painted							2 pole contact
EX4	Overhead	Existing Overhead Garage 2	8' x 8'	0' - 1 1/2"		Existing	Flush	Existing	Painted							2 pole contact
EX5	Overhead	Existing Overhead Garage 3	8' x 8'	0' - 1 1/2"		Existing	Flush	Existing	Painted							2 pole contact
EX6	Overhead	Existing Overhead Garage 4	8' x 8'	0' - 1 1/2"		Existing	Flush	Existing	Painted							2 pole contact
EX7	Swing	Existing Entrance	Storefront	0' - 2"		Existing	Flush	Existing		3	Passage	F75		Yes	Yes	FOB access

Room Finish Schedule

Name	Floor Finish	Floor Base Finish	Wall Material	Wall Finish	Ceiling	Ceiling Finish	Comment
RECEIVING	Resilient Tile	Rubber	Gypsum Wall Board	Painted	2x2 ACT	White	
STORAGE	Resilient Tile	Rubber	Gypsum Wall Board	Painted	2x2 ACT	White	
RESTROOM	Ceramic Tile	Ceramic Tile	Gypsum Wall Board	Painted	GWB	Painted	
STAIR LOBBY	Existing	Existing	Gypsum Wall Board	Painted	ETR	Painted	
CONSULTATION	Resilient Tile	Rubber	Gypsum Wall Board	Painted	2x2 ACT	White	
DISPENSARY SALES AREA	Resilient Tile	Rubber	Gypsum Wall Board	Painted	2x2 ACT	White	
VAULT	Resilient Tile	Rubber	Gypsum Wall Board 16 ga mesh/ cement	Painted	2x2 ACT	White	16 ga steel mesh/ 3/4 plywood/ cement board
RECEPTION	Resilient Tile	Rubber	Gypsum Wall Board	Painted	GWB	Painted	
ENTRY	Resilient Tile	Rubber	Gypsum Wall Board	Painted	GWB	Painted	
STORAGE	Resilient Tile	Rubber	Gypsum Wall Board	Painted	2x2 ACT	White	
BASEMENT STAIR	Existing	Existing	Gypsum Wall Board	Painted	ETR	Painted	
EXISTING GARAGE	Existing	Existing	Gypsum Wall Board	Painted	ETR	Painted	
BREAK ROOM	Resilient Tile	Rubber	Gypsum Wall Board	Painted	2x2 ACT	White	
FULFILLMENT	Resilient Tile	Rubber	Gypsum Wall Board	Painted	GWB	White	

Window Schedule

Mark	Count	Width	Height	Sill Height	Description	Comments
01	1	4' - 0"	3' - 0"	3' - 0"	Teller Glass	Laminated security glass
02	1	3' - 0"	4' - 0"	3' - 0"		One way reflective film
03	10	6' - 0"	6' - 0"	2' - 8"		Existing to remain
04	1	3' - 0"	5' - 0"	4' - 0"		Existing to remain
05	1	3' - 0"	6' - 0"	2' - 5"		Existing to remain

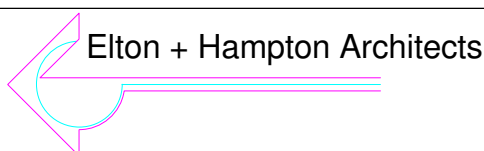
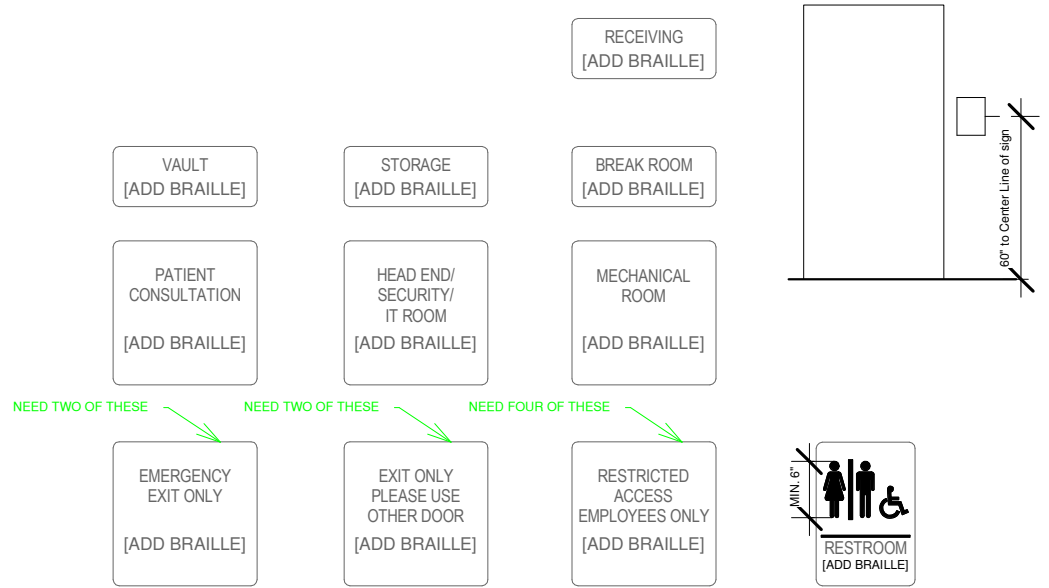
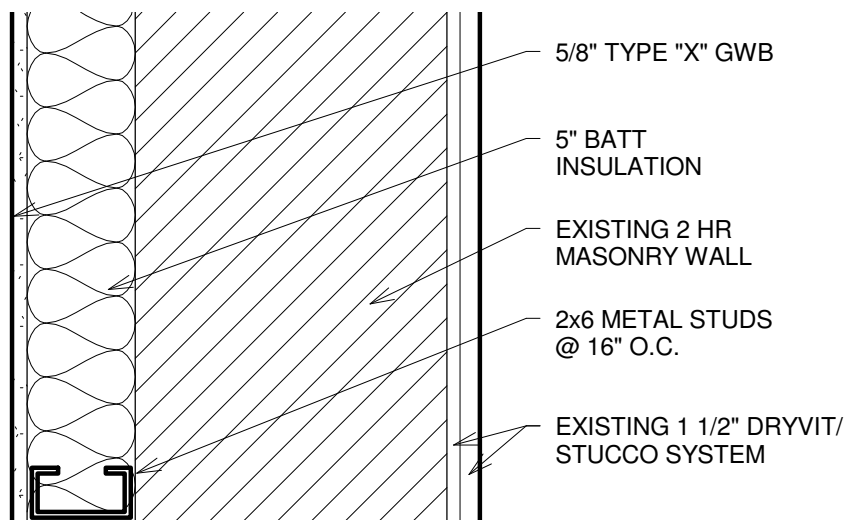
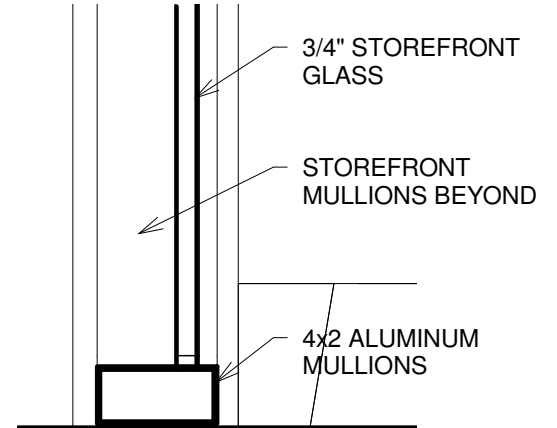
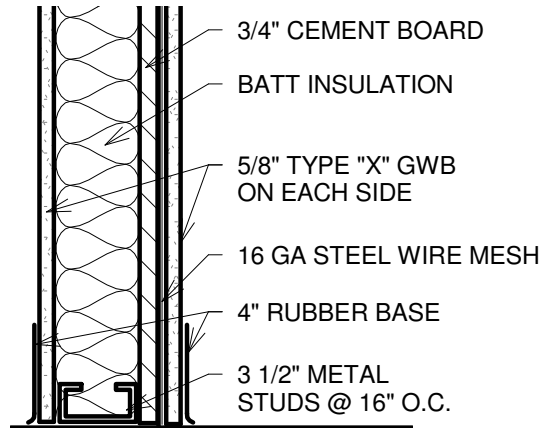
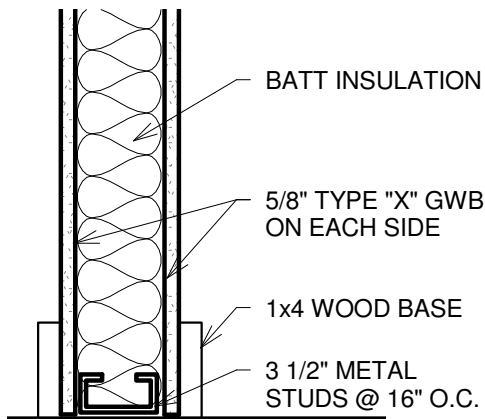

CAS FOUNDATION
67 Broadway
Somerville, MA 02145

Schedules, Wall Types & Interior Signage

Project number	DISPENSARY
Date	12.23.16
Drawn by	M. Worth
Checked by	B. Hampton

A.00.06

Scale As indicated

- Camera 20.00
- Card Reader/Request to Exit/Contact 3.00
- ▲ Keypad 2.00
- Miscellaneous Perimeter 0.00
- Motion 6.00
- ▲ Panic Button 6.00
- ▲ Pin Pad Reader/Request to Exit/Contact 8.00
- Two Pole Contact 4.00

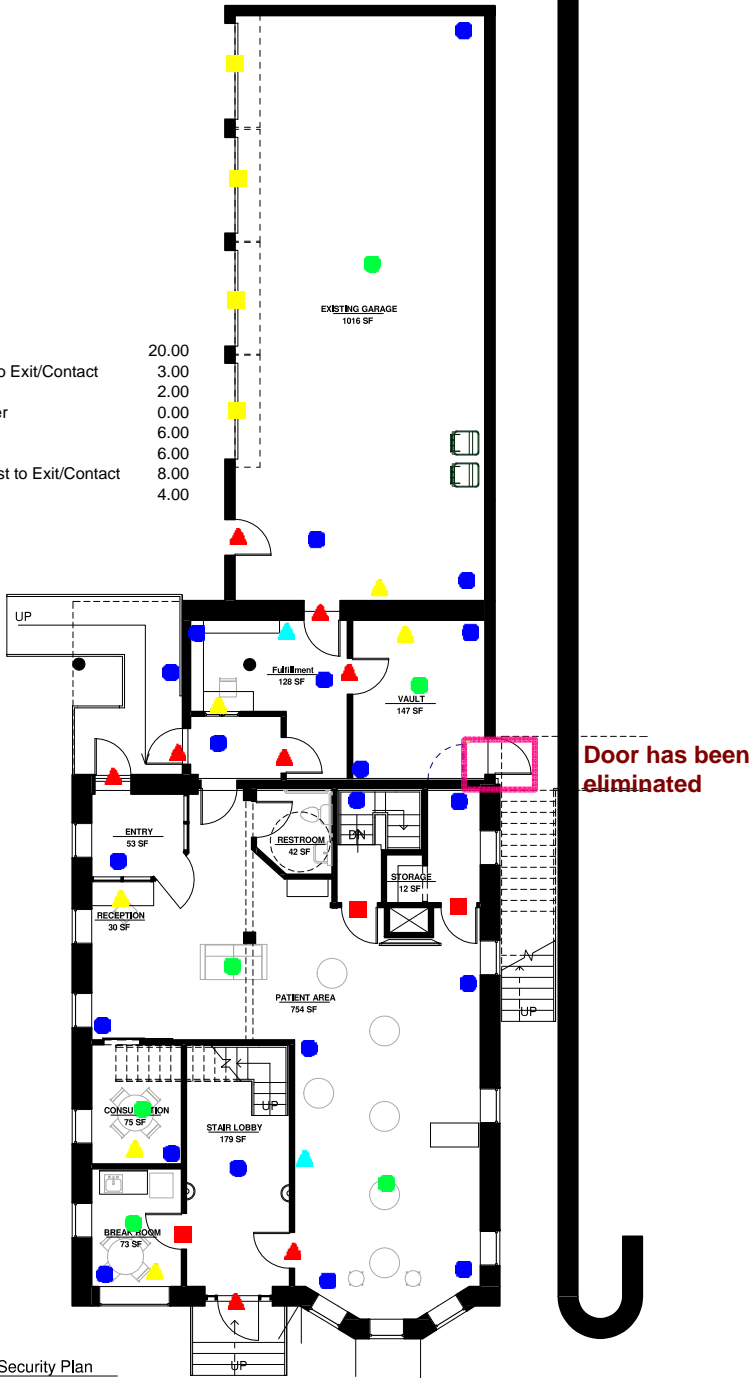

① First Floor Security Plan
1/8" = 1'-0"

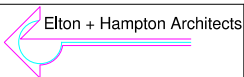

CAS Foundation
67 Broadway
Somerville, MA 02145

First Floor Security Plan

Project number	Dispensary	A.00.08
Date	11.17.16	
Drawn by	Author	
Checked by	Checker	
		Scale 1/8" = 1'-0"